

TIEFENBACH

Control Systems GmbH



Tiefenbach Control Systems GmbH · Rombacher Hütte 18A · D-44795 Bochum

Press information 6-4-2018

Tiefenbach signs large project order for mine Polyak (Turkey) and 3 orders for the newly developed monitoring system CoalCAM®

Tiefenbach Control Systems GmbH has signed a project order on 28-3-2018 for the delivery of an electro-hydraulic control system worth 2.5m \$. The order, which will be delivered completely in June/July 2018 to the manufacturer of the shield equipment ZMJ (Zhengzhou Coal Mining Machinery Group Co. Ltd.) is intended to the mine of the company Polyak Eynez Enerji Üretim Madencilik San. ve Tic A.Ş. in Kinik in the region Soma, Turkey and optionally contains more systems after implementing the first system at customer's site. After the start-up in 2018 the planned production volume is about 5m tons of coal per year, which shall be mined by the LTCC (Long-wall top-coal caving) – method. The signing of the contract is primarily due to the very successful partnership with our agent, the company Labris Madencilik ve San. Ltd. Şti. that exists since the early 2017.

Furthermore, project orders were signed for the camera monitoring system CoalCam®, which is completely independent from other control systems and developed and patented by Tiefenbach (<http://tibacon.com/coalcam>). From mid-2018 CoalCams® will be used in the mines Velenje (Slovenia), Okay North (Australia) and Razpadska (Russia) and will be an integral part of their safety components.

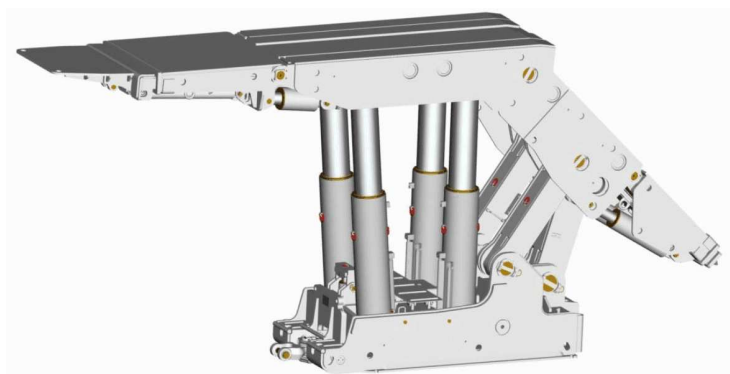

Shield support ZMJ for Polyak



CoalCam

Tiefenbach Control Systems GmbH registered incoming orders of more than 10m € in the first quarter of 2018. The financial year, which ended March 31st, 2018 with a turnover of 30.8m € (+53% previous year) and incoming orders of 38.4m € (+63% previous year) has been successfully completed.

The highest proportion of these turnovers were with customers in Russia, Mexico, China, Kazakhstan, Poland and Turkey.

General company information:

Tiefenbach Control Systems GmbH designs, sells and manufactures electro-hydraulic and hydraulic control systems for applications in the area mining, offshore and heavy industry at the headquarter in Bochum and 4 global subsidiaries with about 120 employees. Tiefenbach is part of the family owned group of companies Knapheide from Beckum with about 1000 employees. With an export quote of >90% Tiefenbach achieved an annual turnover of 30.8m € in the past financial year.

For further enquiry please contact:

Mr Axel Fuisting
Mr Daniel Duda

Management
Marketing

FuistingA@tibacon.com
DudaD@tibacon.com

+49 (234) 777 66 – 0
+49 (234) 777 66 - 310



Rombacher Hütte 18A
D-44795 Bochum

Telefon: +49 234 777 66-0
Telefax: +49 234 777 66-999
info@tibacon.com
www.tibacon.com

Commerzbank AG Essen
DE 91 3608 0080 0401 1144 00
Swift/BIC: DRESDEFF360

Sparkasse Beckum-Wadersloh
DE 35 4125 0035 0000 0310 05
Swift/BIC: WELADED1BEK

USt.-Id.-Nr. DE 8 12 028 647

Geschäftsführer: Dipl.-Kfm. Kai-Uwe Knapheide, Axel Fuisting • Sitz der Gesellschaft Bochum • HRB 11907 beim Amtsgericht Bochum